

LIFTMOORE 3055DXP

30,000 FT.- LB. MOMENT RATING
5,500 LB. MAXIMUM CAPACITY

The Liftmoore 3055 is the ideal midsized crane for those wanting full hydraulic extension plus the efficient planetary winch.

Unlimited power rotation is standard. Rotation is powered through a 45:1 ratio worm gearbox with a bronze worn gear for positive locking and smoothest operation. The crane rotates on a gear bearing slewing ring.

Wireless FM Radio Proportional Controls are standard, complete with "Tethered CAN Wire"

Full Power Extension from 10' to 20'

Power Extension from 10' to 20'

Anti Two-Block

3/8" Galvanized Aircraft Wire Rope

Travel Block w/ Swivel hook

Planetary Gear Winch

Hydraulic Boom Elevation

Model 3055XP-20

Proportional Controls



Wireless Radio Controls Standard

Unlimited Power Rotation

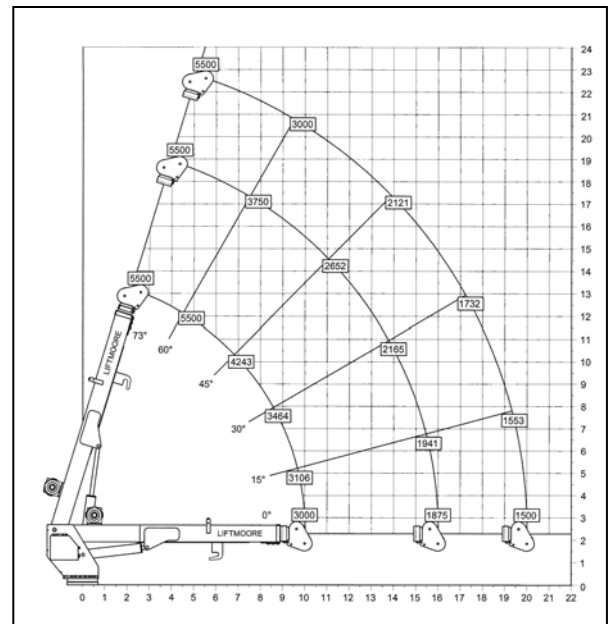

HOUSTON, TEXAS
 FAX: (800) 824-5559 (USA & Canada)
 FAX: (713) 688-6324
 PHONE: (713) 688-5533
 www.liftmoore.com

3055DXP - SPECIFICATIONS

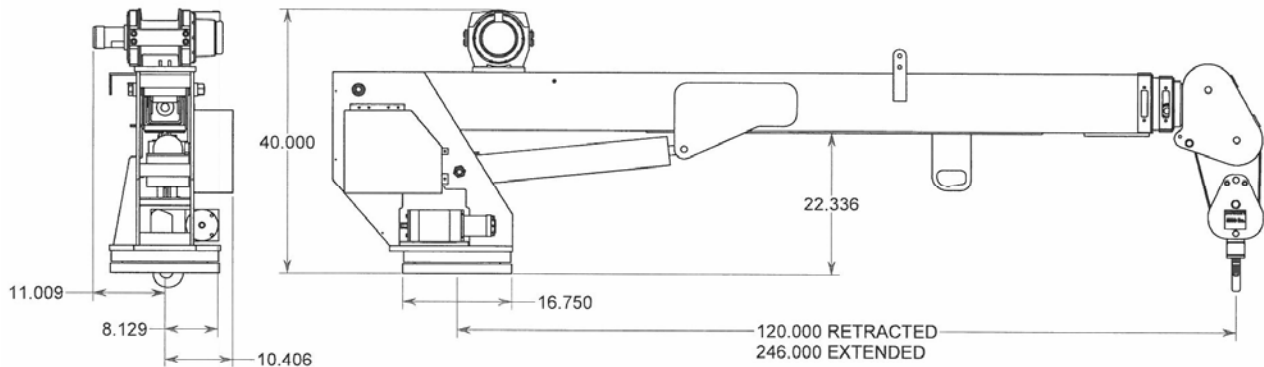

CAPACITY: Moment rating of 30,000 ft.-lbs. with lift capacities as follows.

** 5500 Lbs. @ 5.5 ft.	1875 Lbs. @ 16 ft.
** 3750 Lbs. @ 8 ft.	1666 Lbs. @ 18 ft.
** 3000 Lbs. @ 10 ft.	1500 Lbs. @ 20 ft.
2500 Lbs. @ 12 ft.	

** Two part line required for loads above 2,500 lbs.

HOIST WINCH: The hoist winch is planetary gear design with a 3,000 lb. bare drum capacity. The winch is powered by a low speed, high torque hydraulic motor. Single line no load speed of the winch is 40 ft. per minute at 8 GPM. Ratio between winch drum and wire rope meets ANSI B30.5 requirements.

WIRE ROPE and SHEAVES: The crane is supplied with 95 Ft. of 3/8 in. galvanized aircraft wire rope. Minimum breaking strength of the rope is 14,400 lbs. The wire rope is outside of the boom and visible for operators continual inspection. A 3-ton capacity thrust bearing swivel hook and traveling block for easy two-part hookup is included. All sheaves meet ANSI requirements.

HYDRAULIC SYSTEM: All crane functions are hydraulically powered by an externally (engine) driven hydraulic pump. PTO, Pump, Reservoir and Hoses are not supplied with crane. Flow and Pressure requirements are 8 GPM and 2750 PSI. A proportional hydraulic valve in the manifold controls the crane's speed. All directional control valves are incorporated in a single manifold. A pressure compensated flow control system is used. This system allows excess flow to be dumped at the pressure required by the operating function. This reduces heat build up in the hydraulic oil.

BOOM ELEVATION: The boom is capable of operating from -5 to + 75 degrees. A double acting cylinder elevates the boom. The cylinder has an integral counterbalance valve. The counterbalance valve has three safety purposes. It will hold the cylinder in the event of hose failure, it controls the rate of boom descent and it functions as a relief valve. The cylinder rod is chrome plated and poly seals are used in the cylinder for best possible load holding capability.

BOOM EXTENSION: Extends under hydraulic power from 10 to 20 feet. Two Hydraulic cylinders with an integral counterbalance valve extend the boom throughout its 10-foot extension.

ROTATION SYSTEM: Unlimited rotation is delivered on a gear bearing with an internal gear driven by a worm gearbox. The worm gearbox ratio is 45:1 and it is driven by a low speed, high torque hydraulic motor.

CONTROLS: Supplied with wireless proportional controls, Allowing for precise handling of the load as the operator has control of the function's speed through a trigger switch mounted in the wireless transmitter. Supplied with C.A.N tethering cable

LOAD SENSOR A load sensor is included as standard equipment. The sensor is set to limit overloads when using hoist up, boom extend out & boom down. Boom up is limited by the systems hydraulic pressure setting. When an overload is detected the load can be lowered to reset the overload sensor.

ANTI TWO-BLOCK: The anti two-block is standard on this crane and prevents extending the boom against the travel block with possible breakage of the cable

ELECTRICAL: The 3055 crane's functions are controlled by 12V DC electric solenoid valves. 25 Ft. of 10 gauge wire and a 15 Amp fuse are included.

MOUNTING: A minimum 17,500 Lb. GVWR recommended. Four 7/8" Grade 8 bolts are required. Bolts are not furnished. Mounting plate is 16-3/4" square with a 14-3/4" square bolt Patten.

ACCESSORIES: An outrigger is needed for stability requirements of OSHA 1910.180. The outrigger is necessary to reduce the load on the crane's rotation mechanism and the truck's suspension. A Boom rest is also required. Liftmoore offers both as options.



HOUSTON, TEXAS
 FAX: (800) 824-5559 (USA & Canada)
 FAX: (713) 688-6324
 PHONE: (713) 688-5533
 www.liftmoore.com